

Jet Cooler (Packing Type)

Jet Cooler for installation with special packing.

- JC-TP is for "one-touch" connection with $\phi 4$ tube. JC-RP has screw holes for connection with tube coupler.
- Installation hole diameters are $\phi 10$ and $\phi 13$.
- Please apply soapy water on packing for installation.

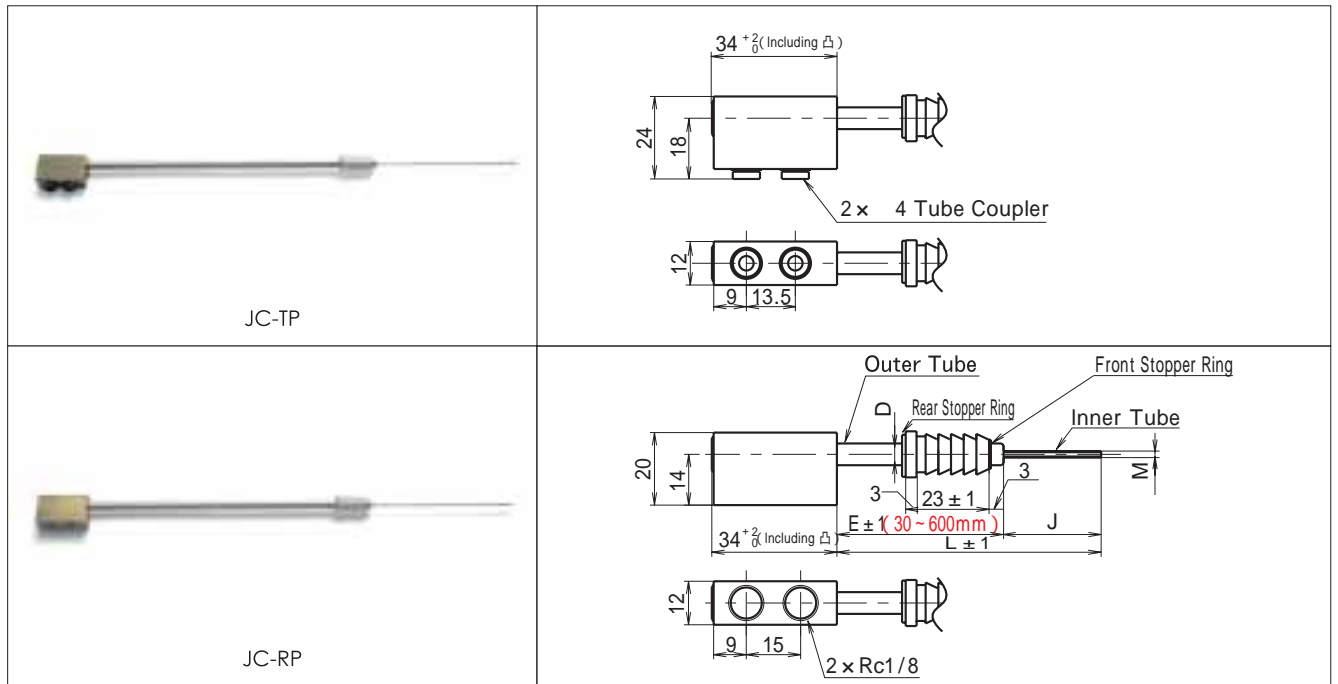

Extra Processing : Coupler will be fitted on RP type.

Material

Head : Bs (Brass)
Outer Tube : SUS304
Inner Tube : SUS304

O-ring (Tube Coupler) : JIS 4-D (Heat-resistance temperature 200°C)
Packing : Silicon Rubber (Heat-resistance temperature 150°C)

Maximum working pressure 1.5MPa Working fluid temperature Below 150°C

Standard list

(Unit : mm)

Model	Type	Nominal	Head Hose Connection	Outer Tube		Inner Tube		Hole for Packing $\phi f^{+0.1}$
				Outer Dia. ϕD	Inner Dia. ϕd	Outer Dia. ϕM	Inner Dia. ϕm	
				JC	TP	106	Tube Coupler	
136	Tube Coupler	6.0	3.0			1.20 1.80	0.85 1.35	13
RP	106	Rc1/8	6.0		3.0	1.20 1.80	0.85 1.35	10
						1.20 1.80	0.85 1.35	
	136	Rc1/8	6.0		3.0	1.20 1.80	0.85 1.35	13
						1.20 2.30	0.85 1.80	

It is recommended to use largest possible inner and outer tubes.
 are standard inner tubes. Please designate M for other tubes.

Jet Cooler (Packing Type)

● Extra processing

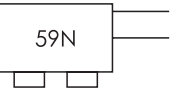
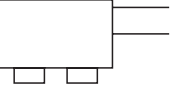
Extra Processing	Extra Processing Code	Example/Remarks
Marking(English letters and numbers only) 4mm high	MK□□□□ Designate letters or numbers	
With Coupler (only JC-RP)	Select from CO•4•6•8 (Only R1/8 Screw) (P.67)	
Inner Tube Designation	M	Select from ϕ M column

● Recommended size

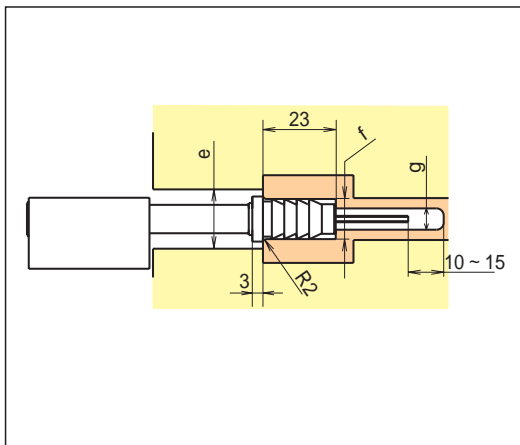

(Unit : mm)

Model	Type	Nominal	Hole on Die Mold	Hole Dia. of Packing	Hole Dia. at Top
			ϕe	$\phi f^{+0.1}$	ϕg
JC	TP RP	106	14	10	3.5~
		136	17	13	3.5~
		138	17	13	4.5~

● Example of order code designation

Model	Type	Nominal	LengthL	OuterLength E	Inner ProtrusionJ	Inner Tube Outer Dia. M	Designate L E J
JC	TP	136	L200	E150	J50	M1.2	※Please order L,E,J by a 1mm unit. M is entry-free in the case of standard.

● Example of order extra processing

Model	Type	Nominal	LengthL	OuterLength E	Inner ProtrusionJ	ExtraProcessing Code
JC	TP	136	L200	E150	J50	MK59N - CO4 - M1.2