

Revolving Jet Cooler

● Characteristics

- Head revolves, and possible to take out tube in desirable direction.
- It is possible to screw in into the die with tube fitted.

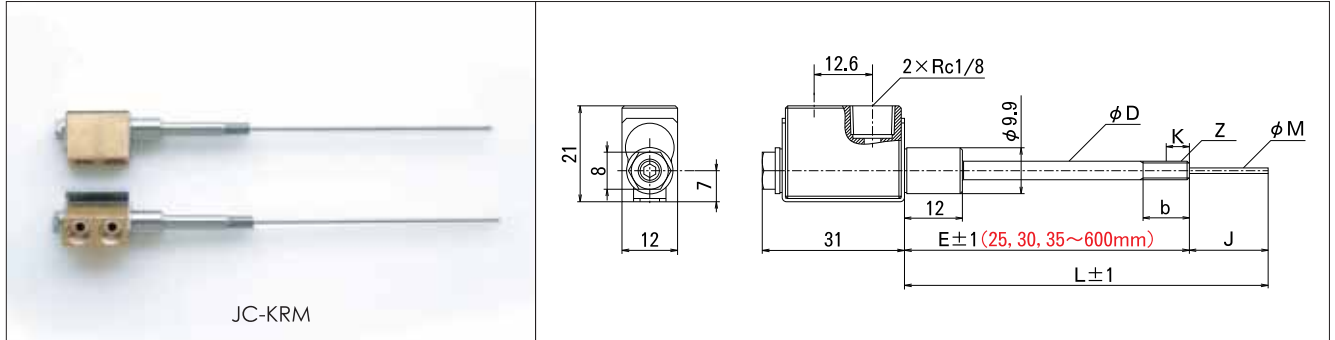

● Material

Head : Bs (Brass)
 Outer Tube : SUS304
 Inner Tube : SUS304

O-ring : JIS 4-D (Heat-resistance temperature 200°C)

● Maximum working pressure 1.5MPa

● Working fluid temperature Below 150°C

● Standard list

Model	Type	Nominal	Head Connecting Hose	Outer Tube					Inner Tube		Head Revolving O-ring
				Outer Dia. φD	Inner Dia. φd	Screw Z	Basic Dia. Location k	Screw Length b	Outer Dia. φM	Inner Dia. φm	
JC	KRM	04	Rc1/8	4.0	2.0	M4	—	10	1.20	0.85	P6
		06		6.0	3.0	M6	—	10	1.20	0.85	
		08		8.0	4.0	R1/16	4	—	1.20	0.85	
				1.80	1.35						
				2.30	1.80						
10	10.0	4.0	R1/8	4	—	2.30	1.80				

It is recommended to use largest possible inner and outer tubes.
 Yellow cells are standard inner tubes. Please designate M for the remaining tubes.

● Product data

The flow rate of revolving Jet Cooler is shown on the right chart.

※The flow rate is measured with JECSS3 ℓ.
 (Both for In and Out fluorine tube φ4-φ2 1m)

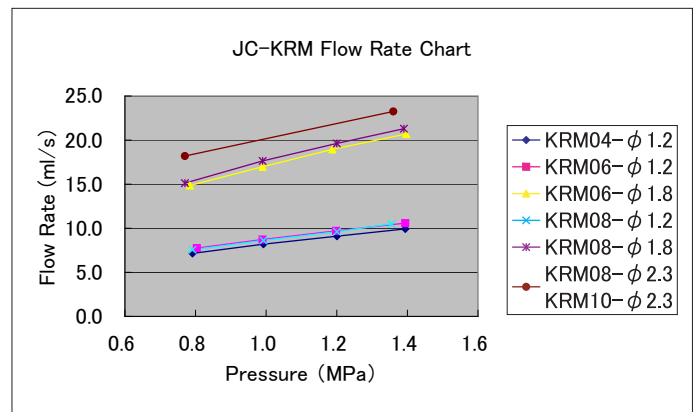

● Torque for tightening

Nominal	Recommended Torque for Tightening (N·m)
04	0.2
06	1
08	4
10	4

■ Note :

- When installing Jet Cooler on the die, please use a nut-driver to protect torque for tightening shown in table.
Using monkey wrenches might damage it.

● Extra processing

Extra Processing	Extra Processing Code	Example	Remarks
Marking(English letters and numbers only) 4mm high	MK□□□□ Designate letters or numbers	59N	Max. 5 letters
With Coupler	CO-4, 6 (Only R1/8 Screw) (P.69)		CO price×2pcs + assembly fee
Inner Tube Designation	M	Select from ϕM column	

● Recommended Mounting Dimensions

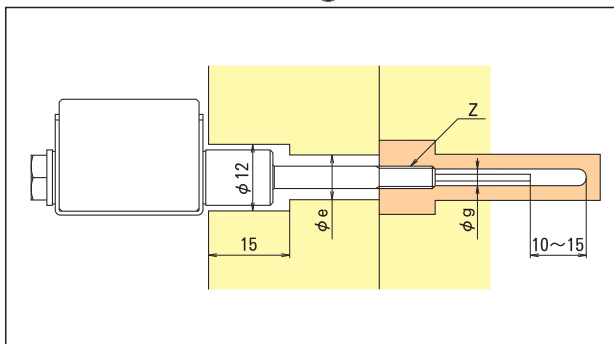

Model	Nominal	Hole on Die Mold	Screw	Hole Dia. at Top
		ϕe	Z	ϕg
JC	04	8	M4×0.7	2.0~
	06	10	M6×1	3.5~
	08	12	Rc1/16	4.5~
	10	12	Rc1/8	4.5~

※Tube Coupler is separately sold. (Please refer to P.69.)

● Example of order code designation

Model	Type	Nominal	LengthL	OuterLength E	Inner ProtrusionJ	Inner Tube Outer Dia. M	Designate L E J
JC	KRM	06	L250	E200	J50	M1.2	※Please order L,E,J by a 1mm unit. M is entry-free in the case of standard.

● Example of order extra processing

Model	Type	Nominal	LengthL	OuterLength E	Inner ProtrusionJ	ExtraProcessing Code
JC	KRM	06	L250	E200	J50	MK59N - C04 - M1.2